



GERMAN SPORT GUNS

Handling and Safety Instructions



Personal Datas:

1. Owner

First Name: _____

Name: _____

Street _____

P.O. Box: _____ Town: _____

Birthday: _____

Place of birth: _____

Passport/number.: _____

Date of gun owner ship: _____

Personal Datas:

2. Owner

First Name: _____

Name: _____

Street _____

P.O. Box: _____ Town: _____

Birthday: _____

Place of birth: _____

Passport/number.: _____

Date of gun owner ship: _____

Informationen of buying the GSG-5

Date of purchase: _____

Buying by: _____

Name: _____

Adress: _____

P.O. Box /Town: _____

Phone: _____

E-Mail: _____

Serial/number of the Weapon: _____

Type/number of the Weapon: _____

Kind of Weapon: _____

Contents

Description:	Section	Page
Product description	D-01	06
Safety regulations	D-01.1	07
Technical data	D-01.2	08-09
Main parts	D-01.3	10-11
Safety mechanisms	D-02	12
Transporting the gun	D-03	12
Handling the gun	D-04	13
General	D-04.1	13
Ammunition	D-04.2	13
Loading the magazine	D-04.3	14
Loading the gun (ready for firing)	D-04.4	15-16
Firing	D-04.5	17
Reloading during firing	D-04.6	18
Unloading the gun (magazine not empty)	D-04.7	19
Unloading the gun (magazine empty, breech open)	D-04.8	20
Decocking the gun	D-04.9	21-22
Sight correction for windage	D-05	22
Gun maintenance	D-06	23
Stripping the gun	D-06.1	23-24
Cleaning the gun	D-06.2	25-26
Gun assembly	D-06.3	27-28
Care of the Gun	D-06.4	29
Trouble shooting, fault removal	D-06.5	30
Servicing	D-06.6	31
Safekeeping and storage of gun	D-06.7	32
Shipping the gun	D-06.8	32-33
Disposal	D-06.9	33
Spare Part List	D-06.10	33
Accessories	D-06.11	34

GSG-5



GSG-5 Carbine

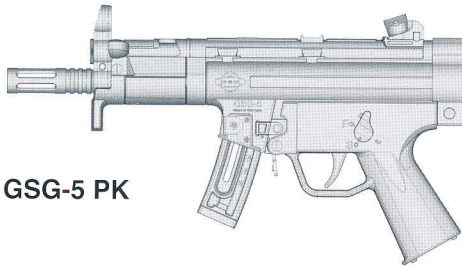

GSG-5 PK

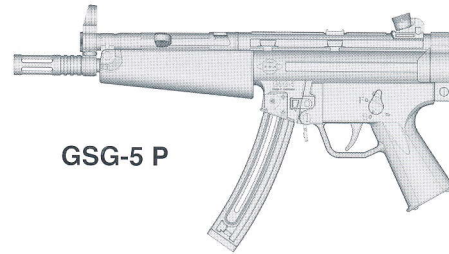

GSG-5 P



GSG-5 SD-Version

D-01: Product Description:

Dear valued customer,

Congratulations on your purchase of a semiauto gun cal. .22 Long Rifle.
This gun is adjusted to high quality utility and high- speed rounds!

In order to create your personal gun, please ask your dealer for the available line of accessories. Furthermore you can find a choice of accessories in this operating manual.

German Sport Guns GmbH
Oesterweg 21
D-59469 Ense-Höingen
Germany

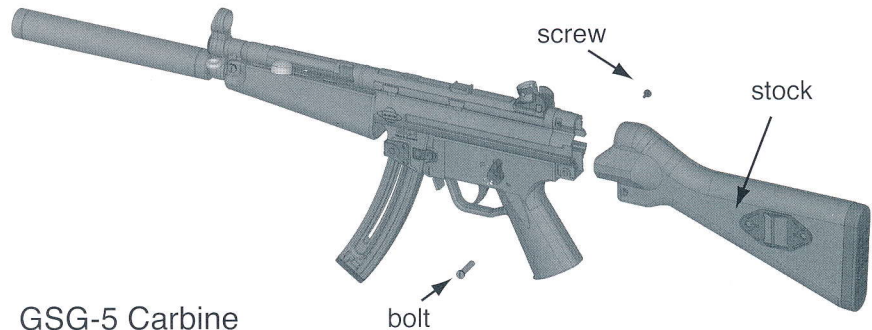

GSG-5 Carbine

D-01.1: General instructions / Safety regulations

Never use the gun under the influence of drugs or alcohol, while ill or suffering other such difficulties. These conditions can impair your powers of judgement and reflexes.

- Always think the gun as being loaded and with the safety off until you have established the opposite through the unloading procedure.
- Always keep the muzzle of the gun in a safe direction when handling. A safe direction is towards an area where there are no people, other life forms or property that is not a recognized target.
- Never point the gun at doors, panes of glass, walls, concrete, stone or flat surfaces (water included). A bullet can penetrate such surfaces or be ricocheted in an unsafe direction.
- Never aim at yourself or other life forms.
- Never rely on safety mechanisms alone. Safety mechanisms are not a substitute for careful, correct and secure handling of the gun.
- Always treat your gun as if the safety mechanisms were not functioning. The best safety precaution is a correct, well-trained and safe handling of the gun.

- Never shoot with a gun which has been penetrated by water, sand, dirt or other foreign bodies.
- Never decock the hammer by holding on to the hammer and pulling the trigger at the same time.
- Never let a loaded gun out of your hand.
- Always unload the gun immediately after firing, before putting the gun away, putting into a holster or handing to another authorized person.
- Never give the gun to a person who has not thoroughly familiarized himself or herself with the safety instructions and handling of gun, by reading the corresponding instructions.
- Never leave the gun lying unattended and protect the gun from unauthorized access.

- Never store the gun loaded, but rather remove the magazine and ensure that no cartridge is left in the chamber of the barrel.

- Always keep the gun and the ammunition separate from one another, and ensure that neither is obtained by unauthorized persons or children.
- Always wear eye and ear protection when shooting.

D-01.2: Technical Data:

GSG-5	Carbine	SD-Version	P
Caliber	.22 Long Rifle HV	.22 Long Rifle HV	.22 Long Rifle HV
Overall length	855 mm	855 mm	474 mm
Overall height	207 mm	207 mm	207 mm
Overall width	53 mm	53 mm	53 mm
Barrel length	414 mm	230 mm	230 mm
Rifling length	406 mm	406 mm	406 mm
Number of grooves	6	6	6
Sight length	340 mm	340 mm	340 mm
Weight without magazine	3060 g	3280 g	2675 g
Magazine weight empty	115 g	115 g	115 g
Trigger pull, approx.	SA 25 N	SA 25 N	SA 25 N
	2,5 kg	2,5 kg	2,5 kg
Magazine capacity / rounds	22/15/10/2	22/15/10/2	22/15/10/2

Included in the delivery are:

- 1 Rifle/pistol
- 1 Magazine
- 1 Handbook
- 1 Multi Tool
- 1 Cleaning Rod
- 1 Stock
- 1 Stock-Fixing-Screw

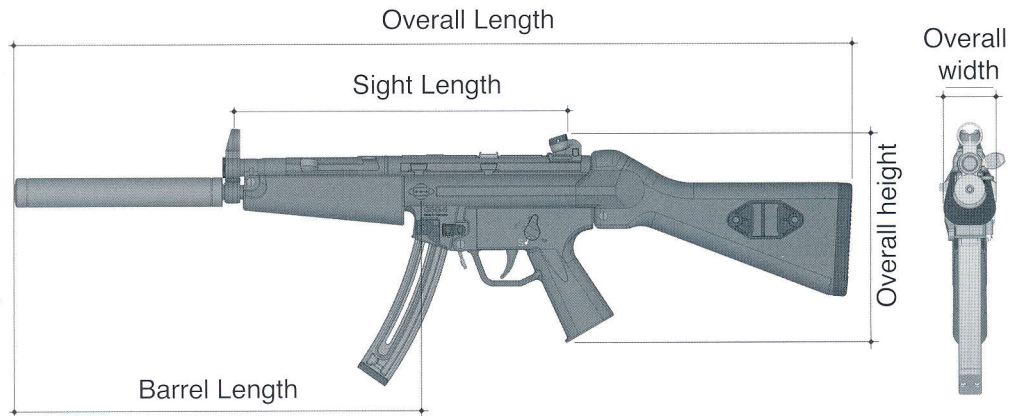

D-01.2: Technical Datas:

GSG-5

PK

Caliber	.22 Long Rifle HV
Overall length	388 mm
Overall height	207 mm
Overall width	64 mm
Barrel length	188 mm
Rifling length	119 mm
Number of grooves	6
Sight length	258 mm
Weight without magazine	2300 g
Magazine weight empty	70 g
Trigger pull, approx.	SA 25 N
	2,5 kg
Magazine capacity / rounds	22/15/10/2

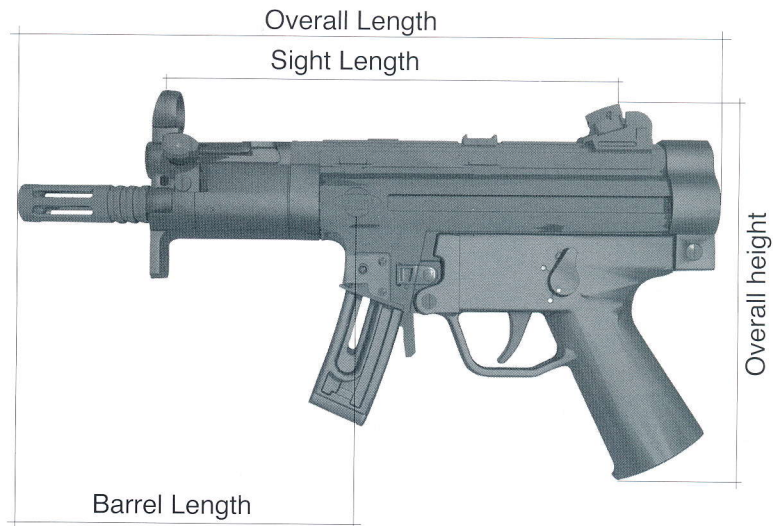

Included in the delivery are:

- 1 Pistol
- 1 Magazine
- 1 Handbook
- 1 Multi Tool
- 1 Cleaning Rod
- 1 Muzzle Cover
- 1 Flashhider
- 1 Key for Muzzle Cover

Main Parts /Assembly groups of GSG-5 PK:

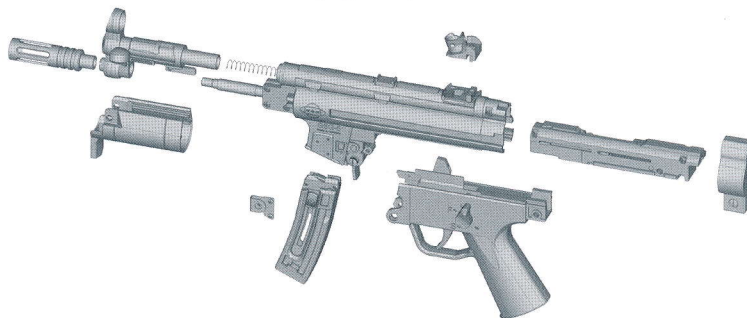

Overall width

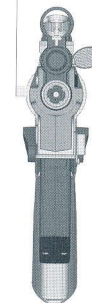

D-01.3: Main parts / Assembly groups of GSG-5 Carbine:

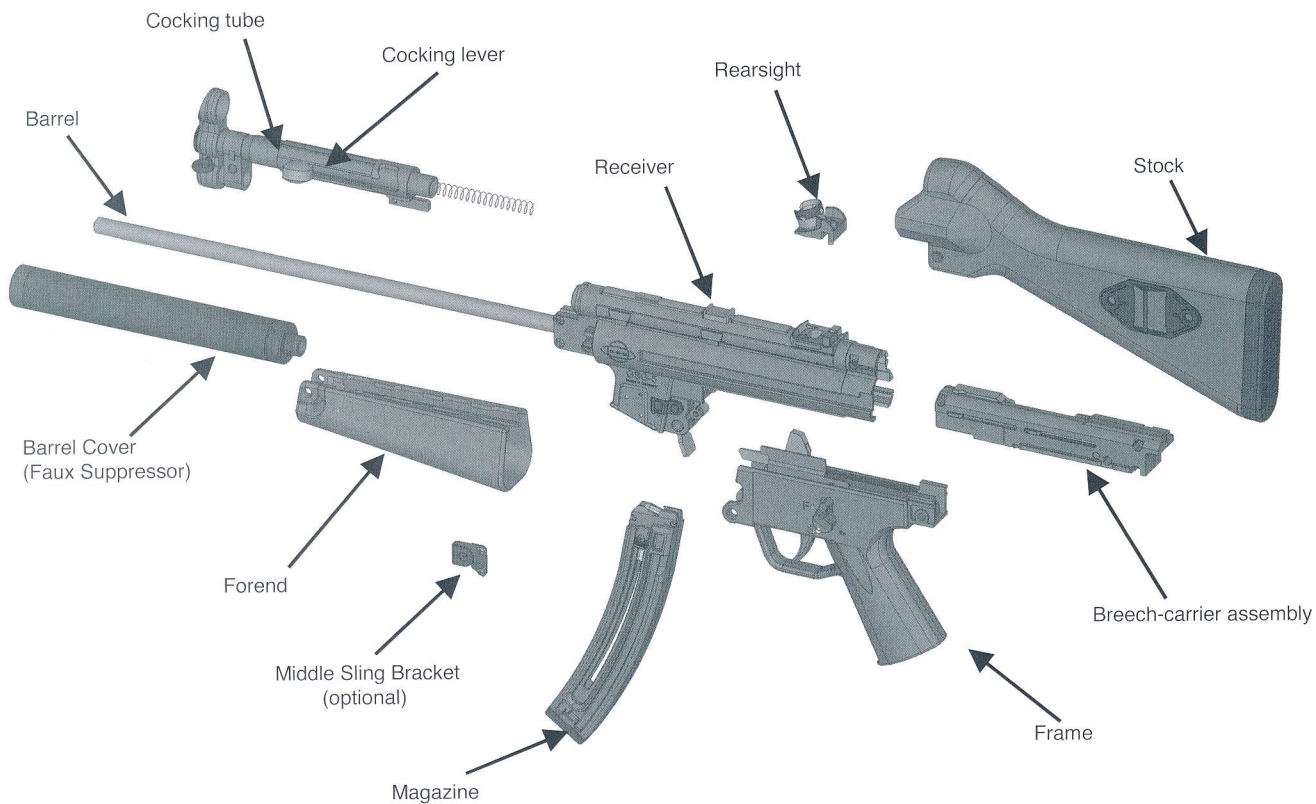

D-01.3: Main parts / Assembly groups of GSG-5 Carbine:

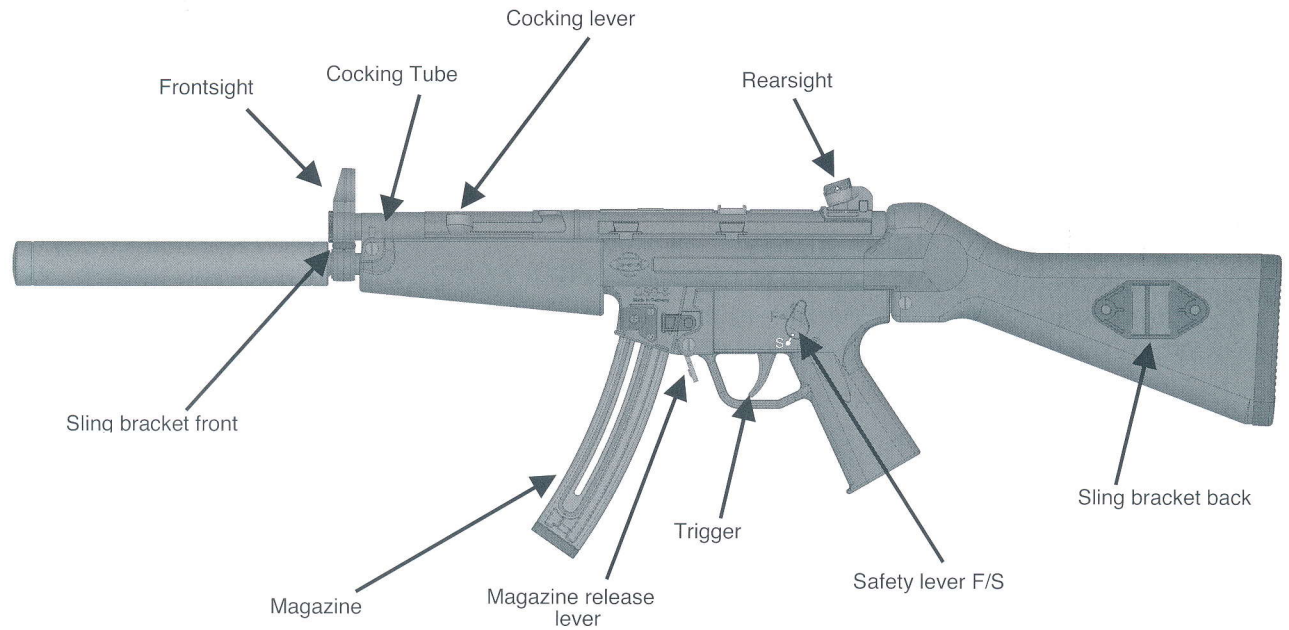

D-02: Safety mechanism:

- “Safety lever F/S“
Engaging manual safety: push the manual safety lever up fully to engage until the yellow point shows on the alphabetic character “S” (see figure 1)
“S“ = SAFE / “F“ = FIRE
- “Magazine Safety“
If you remove the magazine the trigger is blocked.
- “Drop-safety / Firingpin-safety“
An inside safety pin is located in front of the firing pin in order to avoid the firing pin hitting the cartridge, if the weapon is dropped or banged. When the trigger is pulled the safety pin moves forward and releases the firing pin.

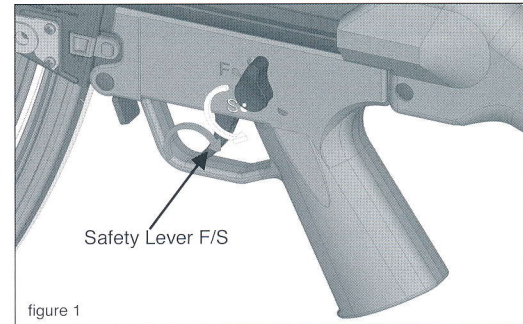

D-03: Transporting the rifle / pistol:

- For your own safety and the safety of others, always transport the gun **unloaded, decocked and closed with the loading strip inside of the chamber.**
- Never carry a gun with you that has already been cocked and which has a round in the chamber.
- Transport the gun separate from the ammunition
- Ensure that all applicable laws governing the transport of firearms are complied with.

D-04: Handling the gun:

D-04.1: General:

The gun is generally delivered preserved with a thin, protective grease and oil coating.

D-04.2: Ammunition:

- For your gun, use only commercial grad ammunition in its original packaging, that correponds with the caliber of the gun. The correct caliber is imprinted on the gun.
- Never use reloaded, refurbished, hand-loaded or non standard ammunition of a different caliber.

- Never use dirty, wet, corroded, bent, damaged or oiled ammunition.

- Never leave the ammunition laying unattended.

Information:

The .22 ammunition spectrum ranges from very light loads for single loader guns to sport load, utility load and on through to high speed rounds. Unfortunately, however, it is not possible to adjust a semi-automatic gun to all loads. We have therefore decided to make an adjustment to the loads that have priority for use with the GSG-5 which are **high quality utility and high-speed rounds.**

Tip: It has been proven that many types of utility and high-speed rounds function more smoothly if the rounds are lightly oiled.

D-04.3: Load the Magazine:

Procedure:

1. Put the cartridge on the feeder, near the magazine feed lips. (figure 2)
2. Pull down the spring of the magazine.
3. Push the bullet to the backside of the magazine. (figure 3)
4. Load only the quantity of bullets into the magazine, you want to fire. (max. 22/15/10 bullets)

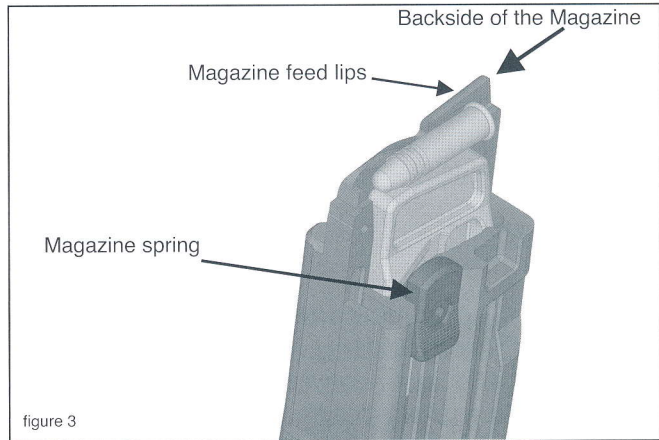
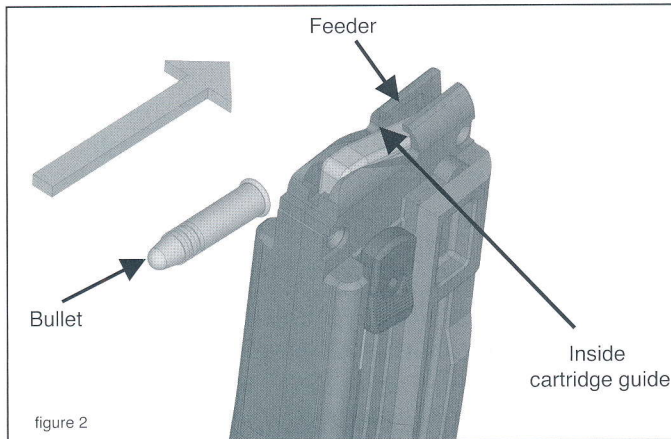

D-04.4: Loading the gun (ready for firing):

Notice:

- The safety lever should always be in the position “S”.
- Never load or reload the gun in a vehicle, a room or another small area. (Except a shooting range).
- Before loading always wipe off an excess grease and oil and check to see if there are any foreign objects/material in the barrel.
- Always keep the muzzle of the gun pointed in a safe direction.
- Do not put your finger on the trigger. Keep your finger outside the trigger guard.
- Load the gun by pushing in the magazine only directly before firing.
- Pull the cocking lever to load the first bullet.
- Never rely on the safety mechanisms alone. Safety mechanisms are not a substitute for careful and correct handling of the gun.
- Never let a loaded gun out of your hand.

Procedure:

1. Point the gun in a safe direction.
 2. Pull the cocking lever back until it stops and allow it to slide forward.
 3. Insert loaded magazine and ensure that it is fully engaged.
 4. Pull the cocking lever back until it stops and allow it to slide forward.
 5. Put the safety lever to the „F“ position.
- The gun is now cocked and ready for firing.

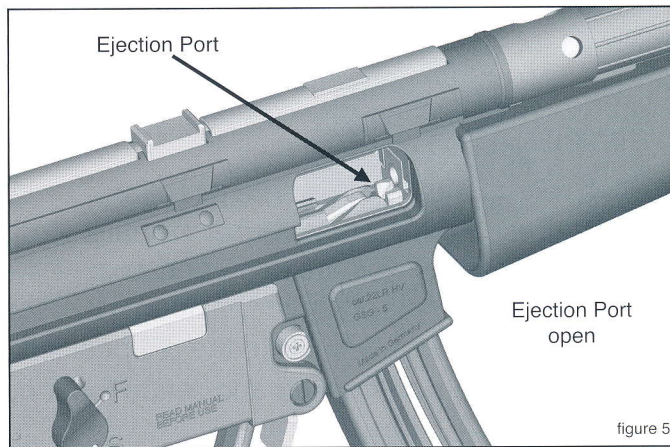
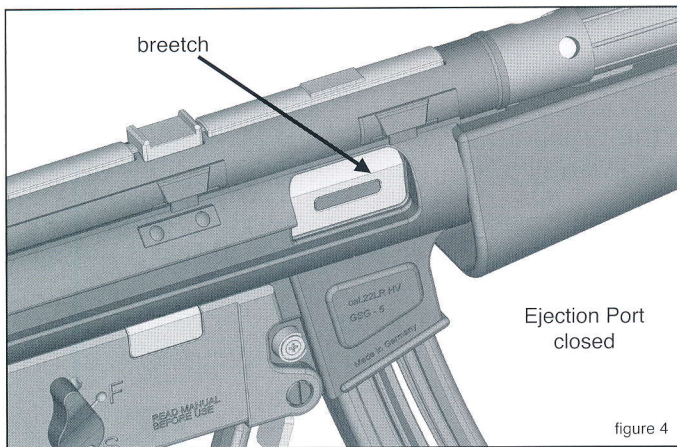

D-04.5: Firing:

1. Ensure that the target and surroundings allow shots to be fired without danger.
2. Be certain when firing that your fingers, hands or other parts of the body are not in front of, above or beside the barrel muzzle or the ejection port.
3. Never allow any person to stand next to you where they could be hit by ejected cartridge cases.
4. When shooting, always wear ear protection and protective eye glasses. Inform other people close to you about the need to wear ear protection.
5. Interrupt shooting immediately and unload the gun if you suspect that a round is not inserted correctly, a case is jammed, a round may have blocked the barrel or a shot sounds or gives the sensation that it may be “weak” or unusual.
6. Never try to dislodge a blockage by firing another round.

Important: During firing hold the gun with the **handguard** and **not with the magazine!**
Holding the gun with the magazine can cause malfunctions !

D-04.6: Reloading during firing:

The slide is held in the open position after the last shot.

Notice:

- Put the safety lever in the position “S”.
- Never let the gun out of your hand.
- Keep the gun in a safe direction.
- Remove the finger from the trigger.

Procedure:

1. Remove the empty magazine.
2. Pull the cocking lever back and turn right into the safety notch (figure 6-7)
3. Insert full magazine and ensure that is fully engaged.
4. Pull the cocking lever back until it stops and allow it to slide forward.
5. The rifle is loaded again and ready to fire.
6. Push the safety lever in the position “F”. The gun is ready for firing.

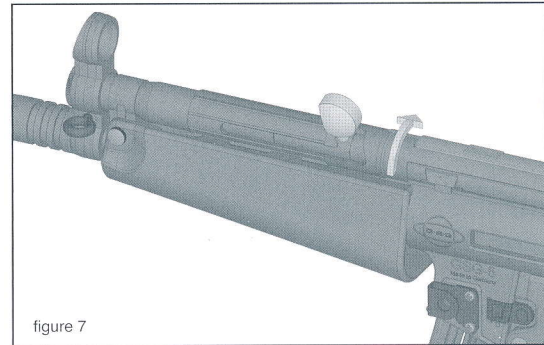
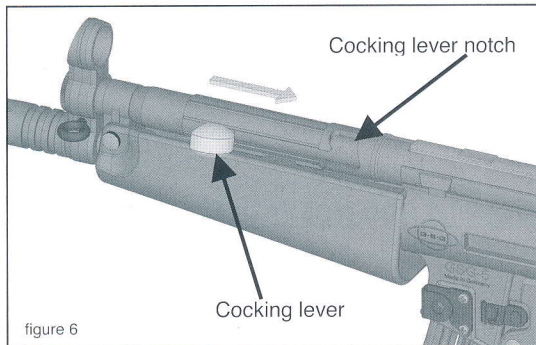

D-04.7: Unloading the gun; magazine not empty

Notice:

- Never let the gun out of your hand before it is unloaded.
- When the gun is loaded; a round is in the chamber.
- Never place your hand over the slide opening.

Procedure:

1. Put the safety lever in the „S“ position.
2. Press the magazine release button to remove the magazine.
3. Keep the muzzle of the gun in a safety direction.
4. Pull the cocking lever back into the safety notch.
The bullet is ejected and the slide is held in the opened position.(figure 7 on page 18.)
5. Check (visually and manually with appropriate aid) to ensure that the round has been ejected
And that there is no round in the chamber.
(figure 8)
6. Empty magazine.
7. Pick up ejected round and clean the gun.

Important: The gun is unloaded, but not decocked !

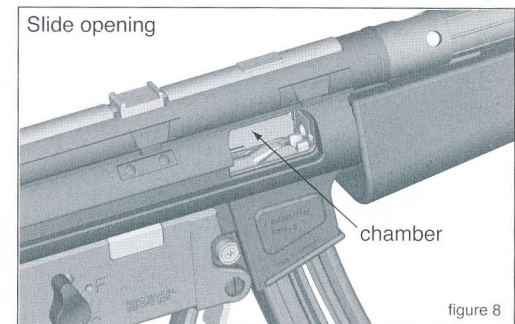

figure 8

D-04.8: Unloading the gun; magazine is empty

Notice:

- You must not let the gun out of your hand until the magazine has been removed and the gun is unloaded.

Procedure:

1. Keep the gun muzzle pointed in a safe direction.
2. Press the magazine release button and remove the magazine.
3. The ejection port must be open after the last round.
4. Check (visually and manually with appropriate aid) to ensure that there is no round in the chamber.

Important: The gun is unloaded, but not decocked!!!

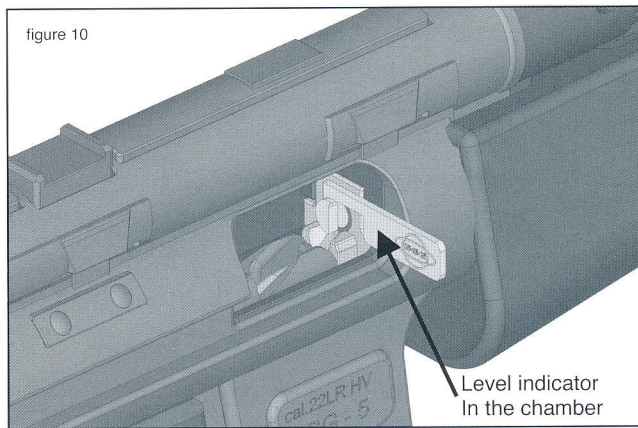
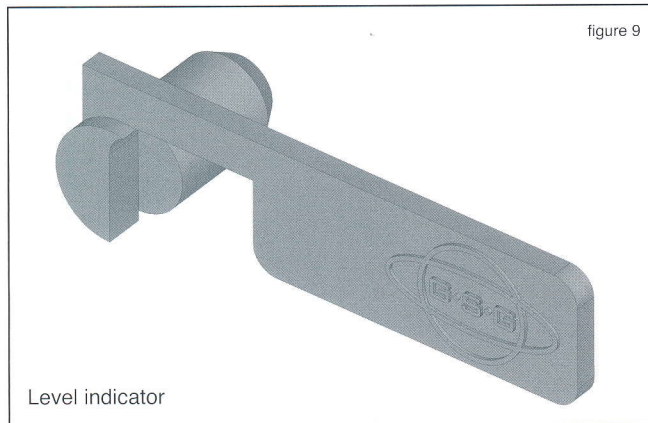

D-04.9: Decocking the Rifle:

Notice:

- You can pull the trigger only, when the empty magazine is engaged in the rifle. Check if the chamber is unloaded !
- The Ejection Port must be open. (The cocking lever is cocked in the safety position.)
- When the Ejection Port is closed, you must put in an empty Magazine and pull the cocking lever in the safety lever notch.

Procedure:

1. When you know, that there is no cartridge in the chamber or in the barrel, then you can turn the safety lever in the position "F".
2. Put the level indicator in the chamber.
3. Pull the cocking lever back until stop and allow to fly forward.
Put the empty magazine in the magazine well.
4. Pull the trigger.
5. The hammer goes into its decocked position. The firing pin hits the level indicator.
6. Now the rifle is decocked.
7. Turn the safety lever in the Position „S“ and remove the empty magazine.

Important: When you push back the cocking lever after this procedure, the hammer goes back and the gun is cocked !

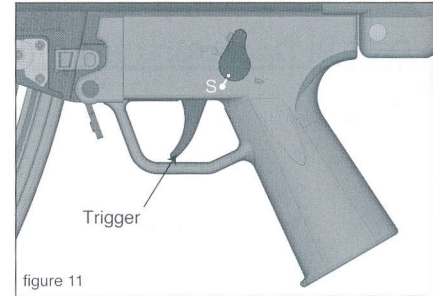

D-05: Setting the Rear Sight

Procedure:

1. Unscrew lightly the cross recess screw on the figure counterclockwise!
2. Turn the slot screw clockwise, to move the rear sight left (at right-hand drift) or turn the slot screw counterclockwise to move the rear sight right (at left-hand drift).
3. When the rear sight is in the best position, screw on the cross recess screw.

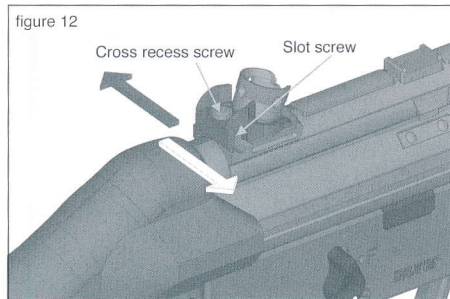

D-06: Maintenance:

D-06.1: Disassemble:

Notice:

- Before disassembling, remove the magazine
- Check, if the rifle is decocked and unloaded, before you begin cleaning it.

Procedure:

1. Check, if the gun is decocked and unloaded.
2. Turn the gun upside down (figure 13)
3. Remove the screws of the stock and of the frame. (figure 13)
4. Check, that the chamber is empty.
5. Remove the stock (figure 14) and unscrew the bolt stop with the multitool. (figure 15)
6. Remove the bolt stop with the multitool or by hand. (figure 16)
7. Remove the grip in the succession 1 and 2 (first right then upwards) as shown in (figure 17)
8. Now you can pull out the breech carrier assembly. (figure 18)

Important: For this procedure, the gun must be decocked!

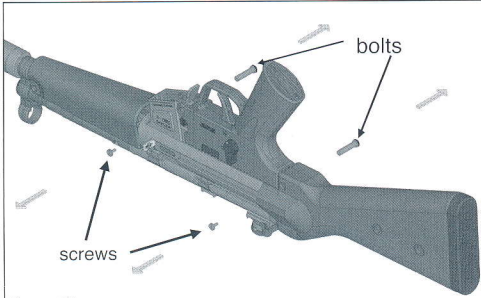

figure 13

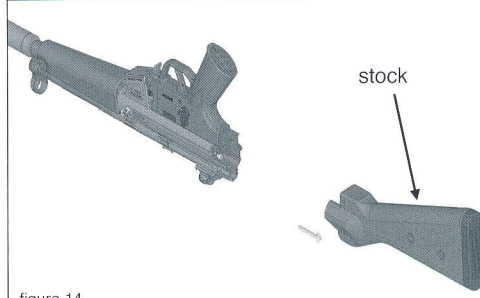

figure 14

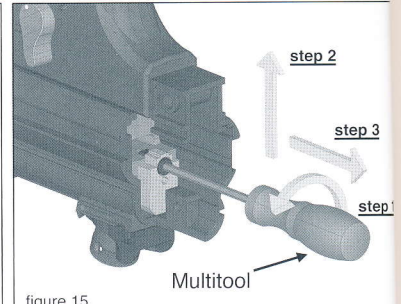

figure 15

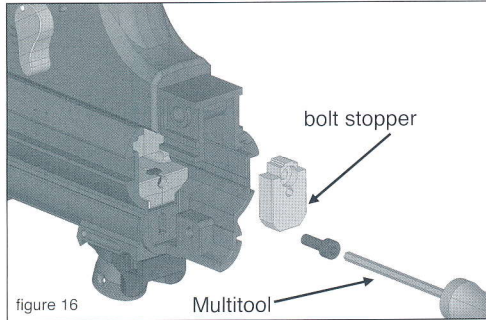

figure 16

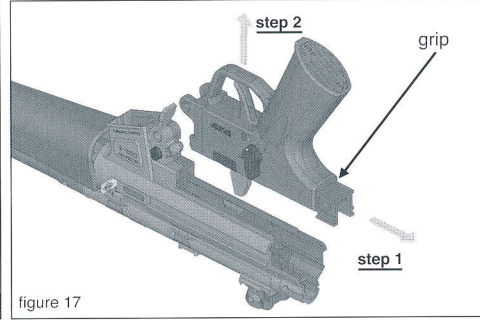

figure 17

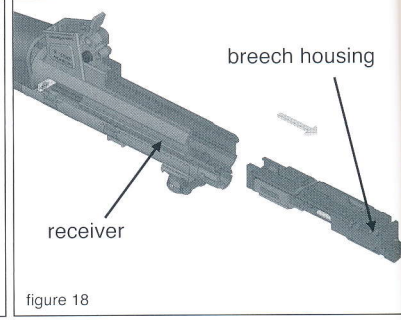

figure 18

D-06.2: Cleaning:

Notice:

- The previously shown disassembling is sufficient for a overall cleaning.
- A further disassembling of the rifle, should only be made by qualified personnel.
- Do not use a steel brush or any other hard material to clean the barrel.
This could damage the flat surface of the barrel.
Use only a suitable cleaning rod and brushes of the right caliber.
- Thinner could damage the surface of the rifle. Before using any cleaner or thinner please note the Advice of the manufacturer.

Procedure:

1. Lubricate the cleaning brush with gun oil and insert it into the barrel via the chamber.
Use the brush to carefully remove all powder residues and dirt in the barrel and chamber.
2. Wipe powder residues and oil from the barrel bore and chamber with cleaning patches.
3. Remove dirt from guides of breech and breech-block with a brush or a cleaning patch and than wipe down with a cloth impregnated with gun oil or gun grease.
4. Lightly oil bore of chamber.

figure 19

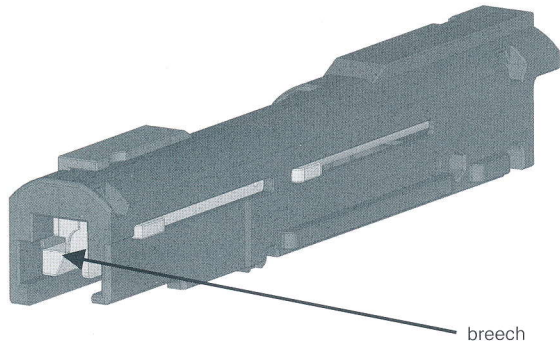

figure 20

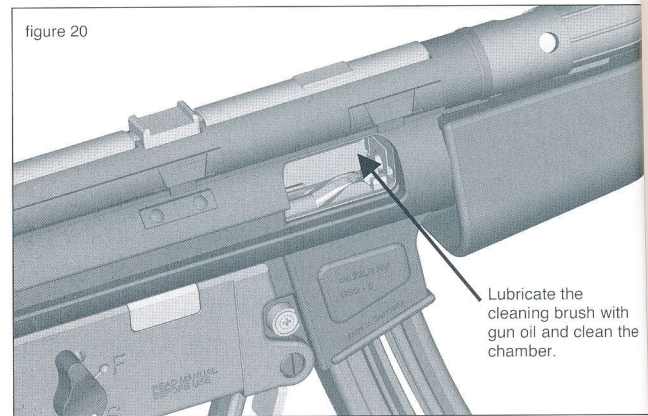

figure 21



D-06.3: Assembling the gun:

Procedure:

1. Push the breech carrier assembly in the slot of the receiver until the position as shown in figure 22. Do not push the breech carrier assembly completely into the receiver (figure 23) !
2. Take now the frame in your hand. Decock the hammer while turning safety lever on position "F" = Fire, pulling the trigger and moving the magazine safety lever backwards as shown in figure 24. The hammer should move now in its decocked position.
3. Turn around the rifle as shown in figure 25 into the upside down position.
4. Attach the trigger group now on the receiver (see figure 25). Check that the trigger group with its grooves will be attached to the rails of the receiver (see figure 25) and follow step 1 and 2 by moving the trigger group left until the bolt holes line up.
5. Now screw on the trigger group.
6. Put the bolt stop part into the receiver with the multitool and move the bolt stop part into its slot exactly in front of the breech carrier assembly (see figure 15 and 16 on page 24).
7. Now you can screw on the bolt stop part to the breech carrier assembly.

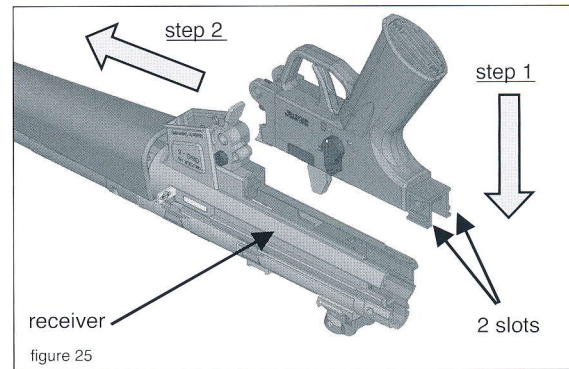
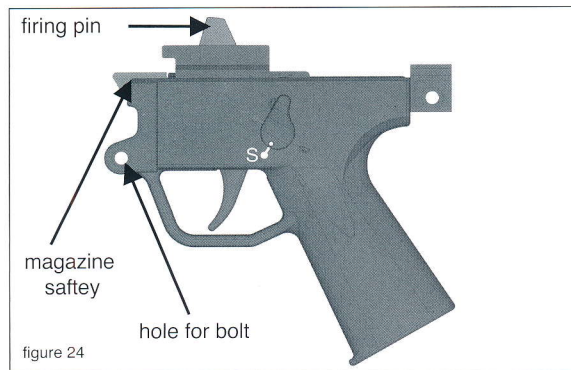
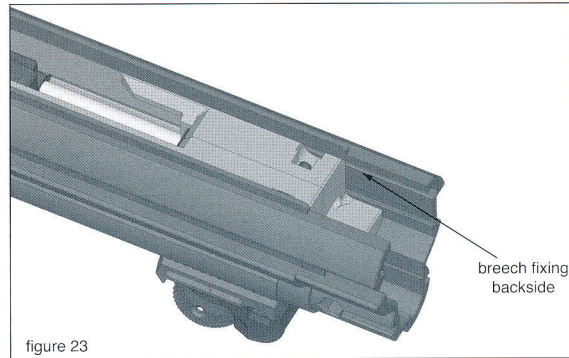
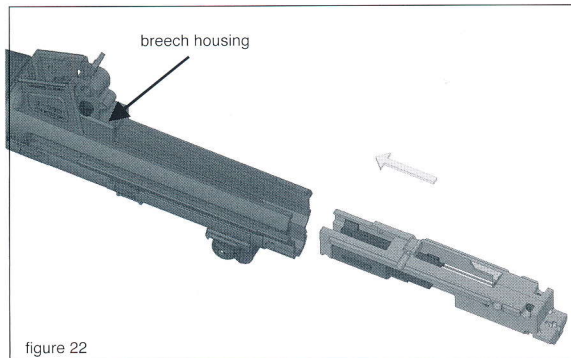

D-06.4: Care of the gun:

Notice:

- Always keep your gun in immaculate condition and in good working order.
- Always clean your gun after use.
- Never modify or repair parts of your gun yourself.
- Have your gun checked once every 12 months by a qualified gunsmith or armourer because defects, wear, corrosion, etc. are not always visible from the outside.
- For repairs or service work, however, we recommend that you return the gun to your dealer / importer who always holds a full range of replacement parts in stock.
- If you order spare parts without returning the gun, you are responsible for ordering the correct part and its correct fitting by a qualified gunmaker or armourer.

D-06.5: Trouble shooting, fault removal:

Gun maintenance (cleaning and inspection) according to the instructions can prevent malfunctions. Should, nevertheless, a malfunction occur during shooting, proceed as follows:

Notice:

Hold the gun pointed in the firing direction (safe direction) and keep your finger off trigger while you carry out the operations described in the following.

Procedure:

1. Pull the cocking lever until it stops, turn the cocking lever into the notch to keep the breech open. (see figure 6+7 page 18)
2. Remove and safeguard the magazine.
3. Verify (visually or with a tool) that there is no bullet, round, case or foreign body in the barrel bore or chamber.
4. If a projectile is locked in the bore, strip the rifle and have the blockage removed with a suitable tool by qualified gunsmith.
5. Remove all rounds, cases or foreign bodies.
6. Clean, lubricate and assemble the rifle.
7. Have the gun inspected by a gunsmith or armourer.

D-06.6: Servicing:

Part /Fault	Possible cause of fault / defect	Possible fault / defect removal
Ammunition feed: No round chambered.	Magazine not properly inserted, deformed or dirty.	Insert Magazine properly or replace it.
Breech: Breech does not close properly.	Gun or rounds dirty or too heavily greased When Rifle still defective. →	Strip, clean and lubricate rifle. Clean or replace ammunition. Repair by manufacturer / gunmaker.
Case ejection: Spent case stuck in chamber or jams in ejection port.	Recoil insufficient because of fouling. Underloaded ammunition. When Rifle still defective. →	Strip, clean and lubricate rifle. Replace ammunition. Repair by manufacturer / gunmaker.
Misfire: Hammer strikes, but no discharge.	Firing pin sticking in it guide. Defective ammunition When Rifle still defective. →	Strip, clean and lubricate rifle. Have gun checked by armorer. Manually cycle slide to chamber new round. Repair by manufacturer / gunmaker.

D-06.7: Safekeeping and storage of the gun:

Warning:

- Always store your gun unloaded and in cleaned condition.
- Store your gun separately from its ammunition and under lock and key.
- The gun and ammunition must not be accessible to children and other inexperienced or unauthorized persons.

D-06.8: Shipping the gun:

Warning:

- Familiarize yourself fully with local legislation governing the shipping and transportation of firearms.

Procedure:

1. Check the gun to ensure that it is unloaded and decocked.
2. Pack the gun well (if possible in its original packaging) to prevent damage in transit.
3. To prevent the gun being recognized as such during shipping, wrap the original packaging in a second outer layer.
4. Do not include carrying cases, telescopic sights, scope mounts or other accessories in the shipment.

5. Enclose a letter stating the following:
 - your full name
 - your full address (mention street, not P.O. Box)
 - your daytime telephone number
 - model and serial numbers of the gun
 - detailed description of the problem encountered or the service work to be performed.
6. Send the gun properly insured and carriage-paid (packages without correct postage will not be accepted) to:
 1. the sales outlet from which you purchased the gun.
 2. the local appointed GSG dealer.
 3. the GSG agent (importer) for your country.

D-06.9: Disposal:

- Strictly observe any current national legislation governing the disposal of handguns.
- When shipping the gun, strictly observe the instructions listed under Sect. **D-06.8**

D-06.10: Spare Part List: (find it under: www.gsg-5.de)

Essential information when ordering spare Parts

- Gun Model (calibre, designation)
- Gun serial number
- Item number and index

D-06.9 Accessories:

- | | | |
|-----|---|-----------------------|
| 1. | Retractable Stock | (Art. Nr.: 202261) |
| 2. | Folding Stock | (Art. Nr.: 202262) |
| 3. | Tactical Handguard with 3 Rails | (Art. Nr.: 202263) |
| 4. | Fore Grip | (Art. Nr.: 202267) |
| 5. | Low Mount | (Art. Nr.: 202268) |
| 6. | High Mount | (Art. Nr.: 202448) |
| 7. | Red-Dot 1x40 for Weaver- & 11mm-Rail | (Art. Nr.: 201754) |
| 8. | Scope 4x28 illuminated reticle, 3 Rails, Mount for Weaver- & 11 mm-Rail | (Art. Nr.: 202399) |
| 9. | Middle Sling Bracket | (Art. Nr.: 201996) |
| 10. | Flashlight Adapter | (Art. Nr.: 202266) |
| 11. | Laser Adapter | (Art. Nr.: 202265) |
| 12. | Magazine Clamp | (Art. Nr.: 202264) |
| 13. | Magazine 2 Rounds | (Art. Nr.: 402 00 09) |
| 14. | Magazine 10 Rounds | (Art. Nr.: 402 00 08) |
| 15. | Magazine 15 Rounds | (Art. Nr.: 402 00 11) |
| 16. | Magazine 22 Rounds | (Art. Nr.: 402 00 07) |
| 17. | GSG-5 PK Tactical Handguard | (Art. Nr.: 202233) |
| 18. | GSG-5 PK Tactical Handguard with Rails | (Art. Nr.: 202269) |

Notice

Service & Distribution

American Tactical Imports Inc.

100 Airpark Drive

Rochester, NY 14624

United States of America

www.americantactical.us

sales@americantactical.us

Phone: 585.328.2212

Fax: 585.328.8184

Manufacturer

German Sport Guns GmbH

Oesterweg 21

59469 Ense-Höingen

Germany

www.gsg-5.de

www.germansportguns.de

info@germansportguns.de

phone: +49 (0) 2938 - 97837-0

fax: +49 (0) 2938 - 97837-130

WARNING!

**THE USE OF CHLORINATED SOLVENTS AND THOSE
CONTAINING ACETONE MAY DAMAGE THE
EXTERIOR FINISH OF YOUR
GSG FIREARM.**



**WE SUGGEST THE USE OF PETROLEUM BASED PRODUCTS
FOR THE CLEANING, PRESERVING, AND LUBRICATING
OF THIS FIREARM, SIMILAR TO WD-40**



AMERICAN TACTICAL IMPORTS